

SAMSON

SAMSON VETEC



Versatile rotary
plug valve for light
industrial applications

Double-eccentric Rotary Plug Valve

Type 62.7

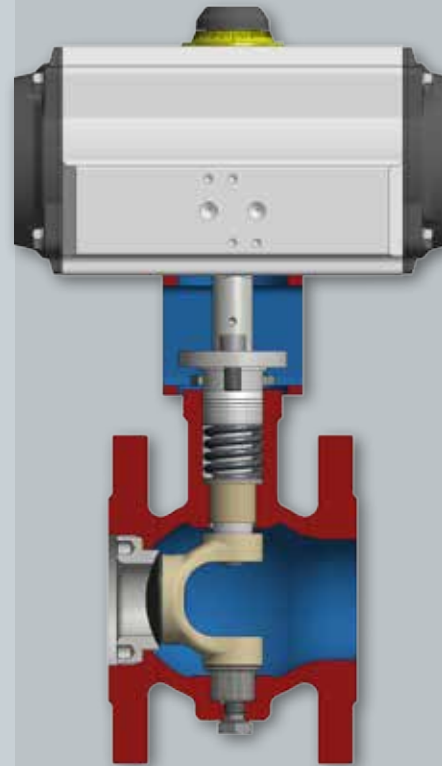

Double-eccentric Rotary Plug Valves

Rotary Plug Valves

- The plug is rotated in and out of the flow path to control either the flow rate passing through the valve or the downstream pressure
- Rotary plug valves are typically used for throttling service due to their excellent control abilities; however, they may also be used for isolation (on/off) applications with tight shut-off
- Different types of pneumatic actuators, electric actuators, or manual handwheels/gears may be used to operate the valves

Double-eccentric Design

- The plug shaft is offset from the centerline of the valve
- The face of the plug is offset from the centerline of the plug shaft

Benefits

- Eliminates friction when the valve is opening or closing
- Reduces wear on internal parts
- Reduces the required breakaway torques
- Allows for more accurate control than other rotary valve types

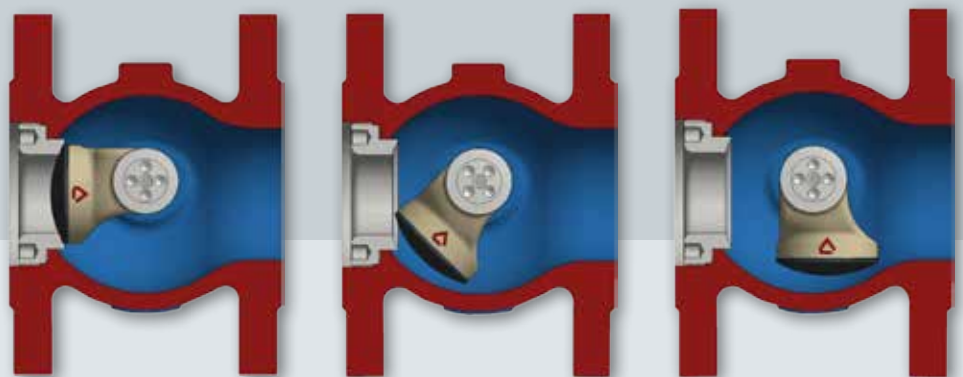
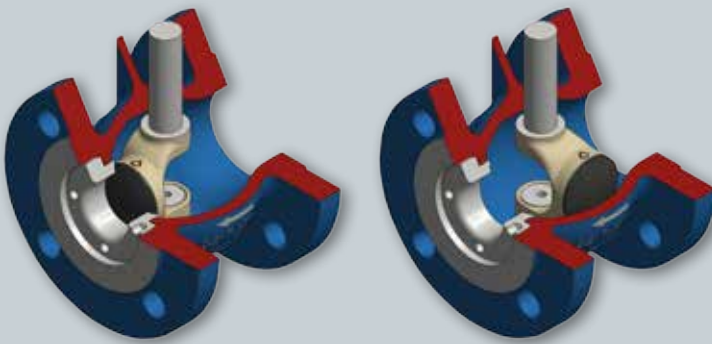

Benefits and Features

Positioners and Accessories

- SAMSON accessories designed for direct attachment
- NAMUR dimensions for easy attachment of third-party positioners or accessories

Low-emissions Packing

- Low-emissions, spring-loaded, self-adjusting packing comes as standard to minimize maintenance requirements and extend the service life

Compact Profile

- The Type 62.7 features a very compact design and much lighter weight than comparable valves, making it ideal for tight spaces and use on prebuilt skids

Maximum Flow Capacity

- The straight-through flow path allows for much higher flow capacities (C_v) than standard globe control valves
- This also allows for a higher rangeability of up to 200:1

Less Flow Disturbance

- Thanks to the free flow path when open, there is less turbulence in the flow and therefore reduced noise as well as less wear and tear on the internal and guiding parts

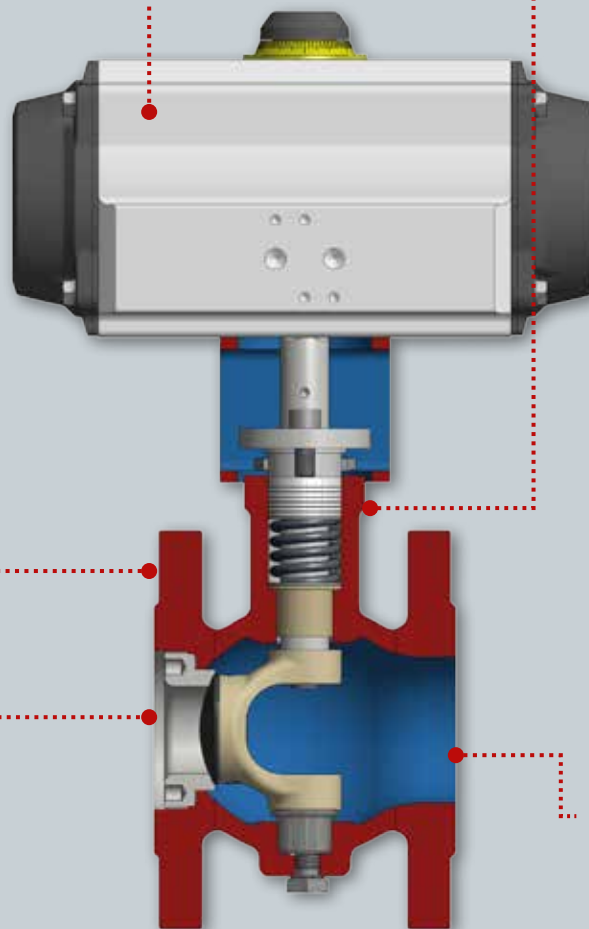

Typical Industries and Applications

Furnace Heating Gas Shut-off Valve

- Industries: chemical, refining
- Applications: heating gas shut-off valve for furnaces in the cracking process and fertilizer production
- Challenges: the valves typically remain open over long periods of time (six weeks to three months) and close only in emergency cases or for shut-downs to clean the furnaces. The feed gas is often contaminated with fine coke dust, which can cause the valves to clog up or seize if they are not designed correctly. On demand, the valves must operate very quickly and reliably
- Solution: the VETEC Type 62.7 is resistant to clogging and seizure thanks to the free flow path and double-eccentric design

Cooling Water Control Valve

- Industries: steel, food and beverage
- Applications: continuous cooling in steel plants or pasteurization in food and beverage production
- Challenges: high-precision cooling water control over a very large rangeability is required to accurately control the temperature in the process
- Solution: the VETEC Type 62.7 offers the highest flow capacities (C_v) among eccentric rotary plug valves on the market as well as a rangeability of 200:1 and high-resolution controllability over the entire control range

Utilities Valve

- Industries: all
- Applications: water, steam, feed gas, etc.
- Challenges: quick availability, simple handling and reliability
- Solution: VETEC maintains large local stocks to offer most valves with the shortest lead times possible. The compact design, accurate control, and high reliability make the VETEC Type 62.7 perfect for utilities applications

Water Recirculation Valve

- Industries: all
- Application: water recirculation for pump protection in fire pipelines
- Challenges: a sturdy design is required to prevent failure and meet the fire protection safety standards. Low-maintenance solutions are preferred to reduce cost and maximize uptime
- Solution: the VETEC Type 62.7 features a strong seat and guiding design with no slack, which means less wear, more precise control, and a more compact design. Additionally, the high rangeability allows for many set points over the full operating range

AHU Flow Control Valve

- Industries: district cooling
- Applications: flow control valves in air handling units (AHU) and chillers
- Challenges: demand on the system fluctuates considerably depending on the time of year (summer to winter) and the number of consumers. Flow control valves play a vital role in helping reduce pump energy consumption despite these drastic fluctuations
- Solution: the high rangeability and reliable operation of the VETEC Type 62.7 are required to maximize system performance. The VETEC Type 62.7 can be used as a stand-alone flow control valve (FCV) or in combination with a SAMSON Type 42 Differential Pressure Regulator as a two-body pressure-independent control valve (PICV) solution



Technical Data

Valve size	NPS 1 to 8
Pressure rating	ANSI Class 150 and 300
Material	A216 WCC (carbon steel) A351 CF8M (stainless steel) A352 LC3 (low-temperature carbon steel)
Flow capacity (CV)	9 to 834
Reduced trim options	0.4
Internal leakage rate (according to ANSI/FCI 70-2)	Metal seat: Class IV Soft seat: Class VI
Temperature range	-76 to 428 °F (-60 to 220 °C)
Face-to-face dimensions	ANSI/ISA S75.08.02 (IEC 60534-2-3)



About VETEC

VETEC Ventiltechnik GmbH is a German company headquartered in Speyer on the Rhine River. The roots of the company date back to 1901. VETEC has been designing, developing, and manufacturing control valves and actuators for industrial processes since 1964.

In 1988, VETEC joined forces with SAMSON, a leading global manufacturer of control valves, actuators, and valve accessories for all industrial processes. VETEC is represented worldwide through the vast network of SAMSON subsidiaries and engineering and sales offices. Flexibility and close proximity to the customer are a vital part of corporate success.

SAMSON subsidiaries comprise VETEC and several other distinguished manufacturers of engineered valves and control equipment: AIR TORQUE, CERA SYSTEM, LEUSCH, PFEIFFER, RINGO VÁLVULAS, SAMSOMATIC, and STARLINE. The wealth of product knowledge and highest regard for quality set SAMSON apart, providing the customer with a single source for all engineered valves.

VETEC designs, develops, and manufactures rotary plug valves in standard and high-alloy materials. Their modularity and flexibility make these valves suitable for many industrial applications. VETEC also offers the VNG high-pressure angle valve for supercritical natural gas applications and the newly developed Type 93.7 Axial Flow Valve for bypass, anti-surge, and pipeline applications.





VETEC Ventiltechnik GmbH
Siemensstraße 12 · 67346 Speyer, Germany
Phone: +49 6232 6412-0 · Fax: +49 6232 42479
E-mail: verkauf@vetec.de · Internet: www.vetec.de

USA Headquarters
4111 Cedar Boulevard · Baytown, TX 77054
Phone: (281) 383-3677 · Fax: (281) 383-3690

Canada Headquarters
1-105 Riviera Drive · Markham, Ontario L3R 5J7
Phone: (905) 474-0354 · Fax: (905) 474-0998