

Type 2408 Excess Pressure Valve

ANSI version

Application

Excess pressure valve for set points from **0.075 psi to 15 psi (5 mbar to 1000 mbar)** · Valves with screwed ends (female thread) $\frac{1}{2}$ NPT, $\frac{3}{4}$ NPT and 1 NPT (G $\frac{1}{2}$, G $\frac{3}{4}$ and G1) · Pressure rating **Class 300 (PN 25)** · Suitable for gases at temperatures from **-5 to +140 °F (-20 to +60 °C)/32 to 300 °F (0 to 150 °C)** ¹⁾

This regulator is used to control the pressure of flammable gases used as a source of energy, e.g. in boilers, driers, vaporizers, heat exchangers or industrial ovens. Alternatively, it can control the compressed air supply in process engineering applications.

An additional application of the regulator is the pressure control of inert gas used for inerting or blanketing reaction or storage tanks to protect the product in the tank from oxidation, explosion or escaping.

To achieve an economical consumption of the inert gas, its pressure must be controlled to always remain slightly higher than atmospheric pressure while the tank is being filled or emptied.

Special features

- Low-maintenance proportional regulators
- Compact regulator design providing excellent control accuracy
- Internal set point springs with set point adjustment using a nut on the actuator
- Spring-loaded, single-seated valve
- Connection $\frac{1}{4}$ NPT (G $\frac{1}{4}$) for control line
- Fulfills stricter fugitive emission requirements (TA-Luft)
- Min. leakage class IV
- Suitable for vacuum

Versions

Valves in $\frac{1}{2}$ NPT, $\frac{3}{4}$ NPT and 1 NPT (G $\frac{1}{2}$, G $\frac{3}{4}$ and G1) · Soft-seated plug · Body made of stainless steel A351 CF8M

Special versions

- Version with FDA-compliant materials for food processing and pharmaceutical industries
- Version to comply with NACE (sour gas)

¹⁾ Version with soft seal and diaphragm made of FPM for air and nitrogen



Fig. 1 · Type 2408 Excess Pressure Valve

Principle of operation

The medium flows through the valve as indicated by the arrow. The position of the valve plug and the area released between the plug (3) and seat (2) determine the flow rate.

In the pressureless state (control line not connected and no pressure applied) the valve is closed by the force of the set point springs (7).

The upstream pressure p_1 to be controlled is tapped upstream of the valve and transmitted over the external control line to the actuator (6) where it is converted into a positioning force. This force is used to move the valve plug according to the force of the set point springs (7). The spring force can be adjusted at the set point adjuster (8).

When the force resulting from the upstream pressure p_1 rises above the adjusted set point, the valve opens proportionally to the change in pressure.

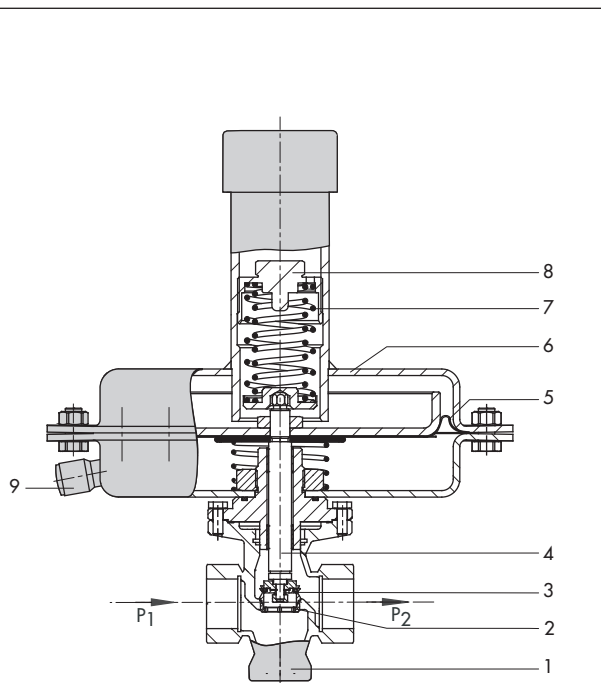

- 1 Valve body
- 2 Seat
- 3 Plug
- 4 Plug stem
- 5 Operating diaphragm
- 6 Actuator housing
- 7 Set point springs
- 8 Set point adjuster (adjusting screw SW 1.1"/27)
- 9 Control line connection G 1/4 (with 1/4 NPT adapter) (upstream pressure p_1)
Turned by 90° in the drawing. The connection is usually located on the left of the valve when viewed from the flow direction.

Fig. 2 · Functional diagram of Type 2408

Installation

Preferably the regulator is to be installed in horizontal pipelines:

- Actuator housing on top of the valve, facing upwards
- The direction of medium flow must correspond with the arrow on the valve body.
- In applications in which the blanketing gas can liquefy, condensate may form in the control line, causing damage to the regulator. To allow condensate to run back into the tank, install the control line with an approximate 10 % slope to the pressure tapping point at the tank.
- Distance between the pressure tapping point and regulator min. 2 x NPS.



In exceptional cases, the regulator can also be installed in vertical pipelines with the direction of flow from the bottom to the top.

Refer to EB 2528 EN for more details.

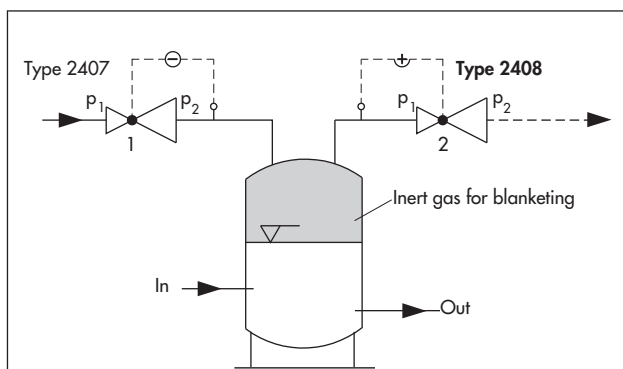

If the pressure p of the inert gas in the tank falls below the set point adjusted at the Type 2407 Pressure Reducing Valve (1), it opens to allow more gas to enter the tank. The valve (1) closes again when the pressure p of the blanketing gas has been re-established.

If the pressure is too high, the inert gas is vented off over the **Type 2408** Excess Pressure Valve (2).

Fig. 3 · Typical application, Type 2408 used for tank blanketing

Table 1 · Technical data

Thread size	½ NPT, ¾ NPT and 1 NPT (G ½, G ¾ and G1)
Pressure rating	Class 300 (PN 25)
Control line connection	G ¼ (with ¼ NPT adapter)
C _v coefficients	0.3 · 1.2 · 3.0 · 3.8 ¹⁾ · 6.0 ¹⁾
K _{vS} coefficients	0.25 · 1.0 · 2.5 · 3.2 ¹⁾ · 5.0 ¹⁾
Max. perm. differential pressure Δp	90 psi (6 bar)
Max. perm. pressure at the actuator Actuator area A = 186 in ² (1200 cm ²) Actuator area A = 100 in ² (640 cm ²) Actuator area A = 50 in ² (320 cm ²) Actuator area A = 25 in ² (160 cm ²)	7.5 psi (0.5 bar) 15 psi (1 bar) 30 psi (2 bar) 60 psi (4 bar)
Max. perm. temperature range (medium temperature)	-5 to +140 °F (-20 to +60 °C) · 32 to 300 °F (0 to 150 °C) ²⁾
Leakage class acc. to DIN EN 60534-4	Soft-seated plug, minimum class IV
Set point ranges	0.075 to 0.25 psi · 0.15 to 0.42 psi · 0.35 to 0.87 psi · 0.75 to 3 psi 1.5 to 15 psi
	5 to 15 mbar · 10 to 30 mbar · 25 to 60 mbar · 50 to 200 mbar 100 to 1000 mbar

¹⁾ Only in conjunction with 1.5 to 15 psi (100 to 1000 mbar) set point range

²⁾ Version with FPM soft seal and FPM diaphragm for air and nitrogen

Table 2 · Materials · Material number acc. to DIN EN

Body	Stainless steel A351 CF8M · 1.4408
Seat	316L
Plug	316L with soft sealing
Plug sealing	EPDM · FPM · NBR
Operating diaphragm	EPDM · FPM · NBR
Positioning spring and set point springs	1.4310 K
Actuator housing	1.4301

Dimensions

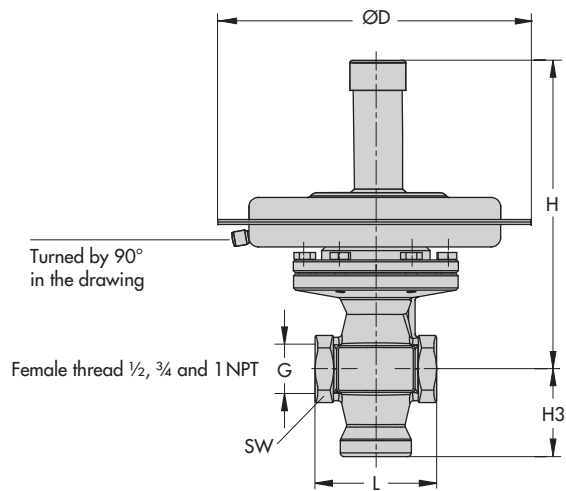

Thread size		1/2 NPT	3/4 NPT	1 NPT
Female thread		1/2"	3/4"	1"
Face-to-face dimension L		2.6" (65 mm)	3" (75 mm)	3.5" (90 mm)
Width across flats SW		1.3" (34 mm)	1.3" (34 mm)	1.8" (46 mm)
Height H3		1.8" (45 mm)		
0.075 to 0.25 psi (5 to 15 mbar)	Height H	14.2" (360 mm)		
	Actuator	Actuator ØD = 19.3" (490 mm), actuator area A = 186 in ² (1200 cm ²)		
0.15 to 0.42 psi (10 to 30 mbar)	Height H	14.2" (360 mm)		
	Actuator	Actuator ØD = 15" (380 mm), actuator area A = 100 in ² (640 cm ²)		
0.35 to 0.87 psi (25 to 60 mbar)	Height H	14.2" (360 mm)		
	Antrieb	Actuator ØD = 15" (380 mm), actuator area A = 100 in ² (640 cm ²)		
0.75 to 3 psi (50 to 200 mbar)	Height H	14.2" (360 mm)		
	Actuator	Actuator ØD = 11.2" (285 mm), actuator area A = 50 in ² (320 cm ²)		
1.5 to 15 psi (100 to 1000 mbar)	Height H	14.2" (360 mm)		
	Actuator	Actuator ØD = 8.9" (225 mm), actuator area A = 25 in ² (160 cm ²)		
Weight, approx.	Set point range 0.075 to 0.87 psi (5 to 60 mbar)	34.3 lb (15.5 kg)	34.6 lb (15.7 kg)	35 lb (15.9 kg)
	Set point range 0.75 to 15 psi (50 to 1000 mbar)	26.5 lb (12 kg)	26.9 lb (12.2 kg)	27.3 lb (12.4 kg)

Fig. 4 · Dimensional drawings of Type 2408

Ordering text

Type 2408 Excess Pressure Valve

Thread size ... NPT (G ...)

Set point range ... psi (bar, mbar), C_V (K_{V5}) coefficient ...

Body material ...

Material:

Plug sealing ..., operating diaphragm ...

Optionally, special version ...

Specifications subject to change without notice



SAMSON AG · MESS- UND REGELTECHNIK
Weismüllerstraße 3 · 60314 Frankfurt am Main · Germany
Phone: +49 69 4009-0 · Fax: +49 69 4009-1507
Internet: <http://www.samson.de>

T 2529 EN

2013-07